

MANUALLY CONTROLLED DUMPING

OUTPUT  
LVGFB1200 2 TPH \*\*  
SAND 1.7-3.4MM  
SAND 1.7MM  
SAND 1.1MM  
SAND 0.6MM  
SAND <0.3MM

OUTPUT  
LVSCS1000 2 TPH \*\*  
GLH80 POURING HOPPER  
REMOVES >3.4MM AND LABELS AND DEBRIS  
SAND <3.4MM APPROX 2 TPH \*\*

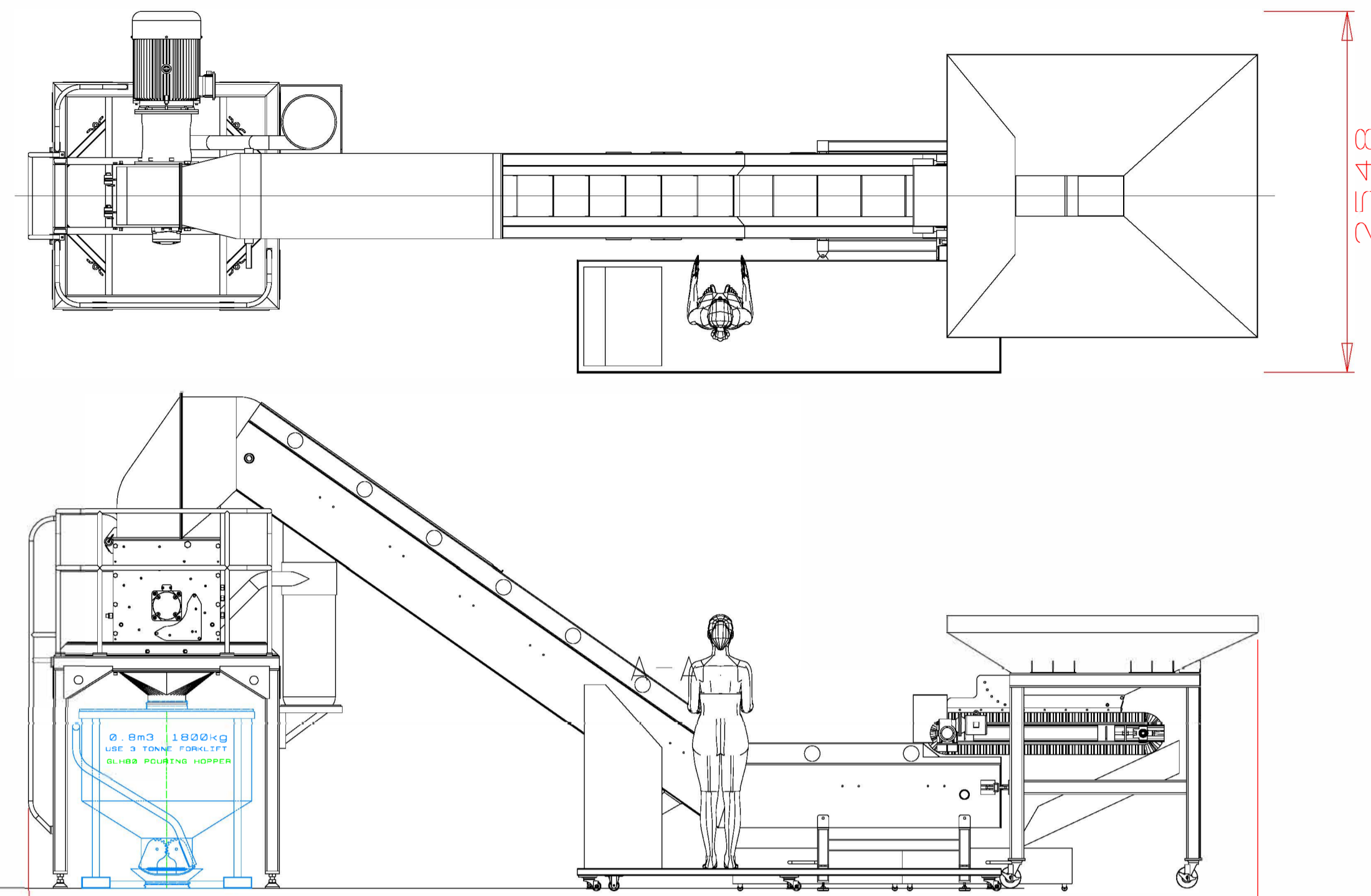

OUTPUT  
TO PE 1M3 BAGS OR  
GLH80 POURING HOPPER  
CULLET AVERAGE <50MM 3-7 TPH \*\*  
OR SAND < 5MM 2-5 TPH \*\*

EXPLECO  
Limited  
expleco.com

AFSMaxi  
Glass Bottle Crusher

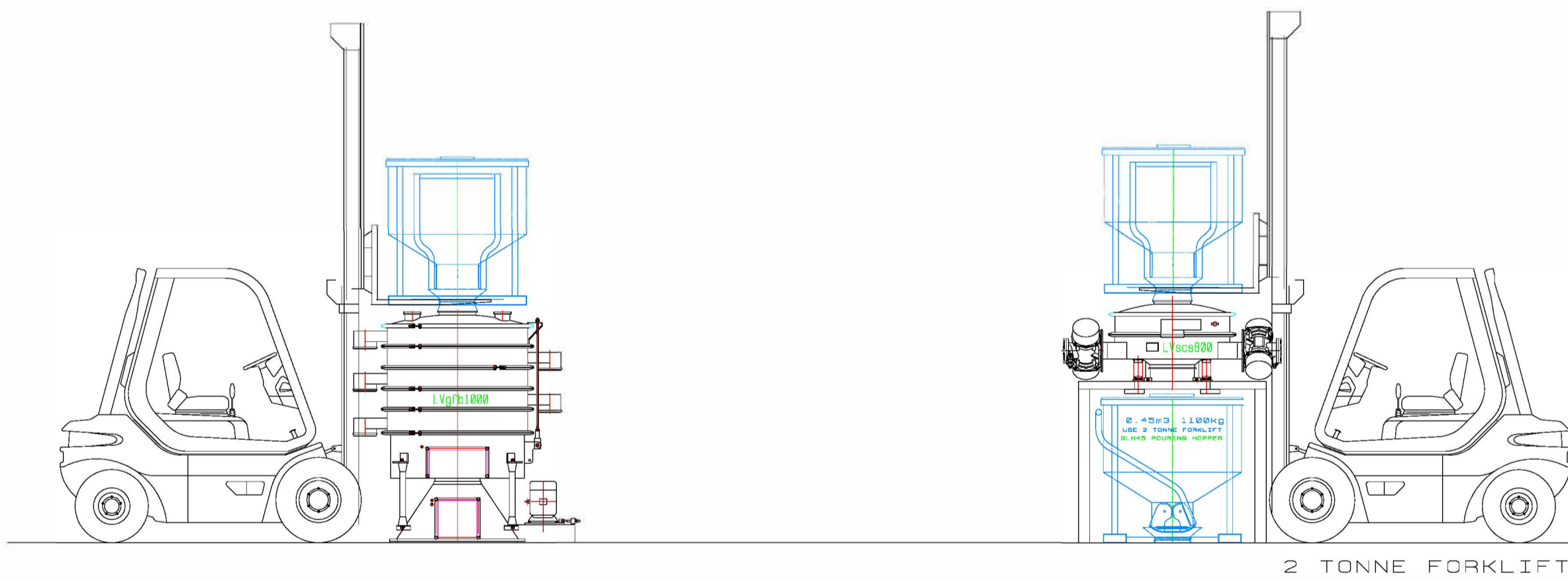
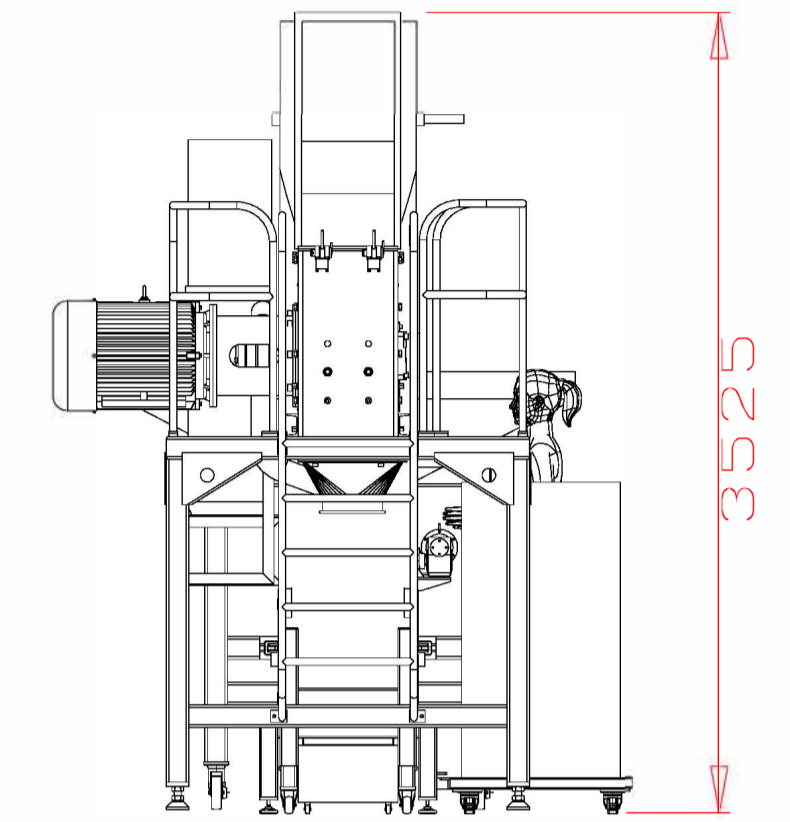

OUTPUT  
LVGFB1000 1 TPH \*\*  
SAND 1.7-3.4MM  
SAND 1.7MM  
SAND 1.1MM  
SAND 0.6MM  
SAND <0.3MM

OUTPUT  
LVSCS800 1 TPH \*\*  
GLH45 POURING HOPPER  
REMOVES >3.4MM AND LABELS AND DEBRIS  
SAND <3.4MM APPROX 1 TPH \*\*

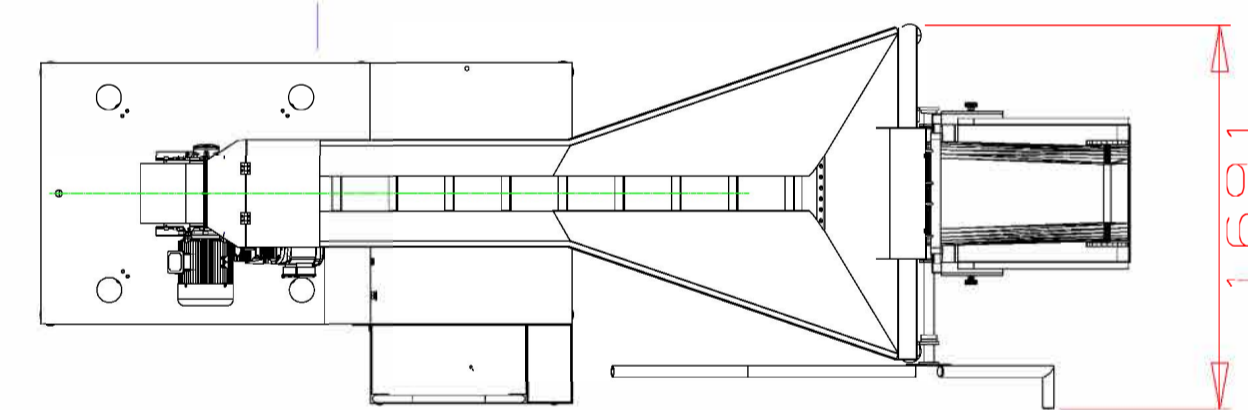

OUTPUT  
TO PE 1M3 BAGS OR  
GLH45 POURING HOPPER  
SAND 1-2 TPH \*\*

EXPLECO  
Limited  
expleco.com

AFSMini  
Glass Bottle Crusher

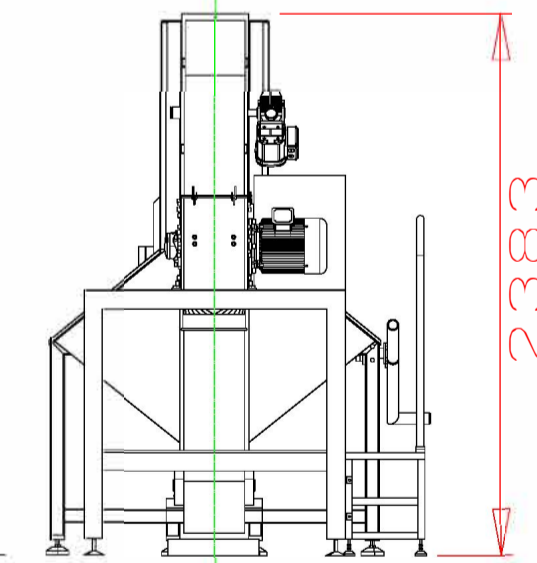

\*\* INDICATES TONNES PER HOUR CAPABILITY OF EACH MACHINE. THIS TONNAGE IS A WIDE ESTIMATE DUE TO GREAT VARIANCE DEPENDING ON BOTTLE TYPES, SAND HUMIDITY AND CONTAMINANT DEBRIS THAT MAY BE IN THE PROCESS LINE

Copyright ©

This drawing must not be copied nor used for manufacturing purposes without the written permission of EXPLECO LTD. Neither is it to be handed over to or communicated to a third party. INFRINGEMENT WILL LEAD TO PROSECUTION

EXPLECO GLSMAXI GLSMINI Comparison

PROCESS EQUIPMENT OPTIONS AND LAYOUT

EXPLECO  
Limited

31 WINDHAWK RISE, RD2 BLENHEIM 7272  
NEW ZEALAND www.expleco.com

SCALE 1:33 on A1 DATE 15-06-21

DRAWN BY TJFB CHECKED TJFB

SHEET NUMBER 001 DESIGN NUMBER

2

3

4

5

6

7

8